

# SERVICE

# H32DC

- PORTABLE
- QUICK TOOL CHANGE
- RELIABLE
- ONLY 67 KG

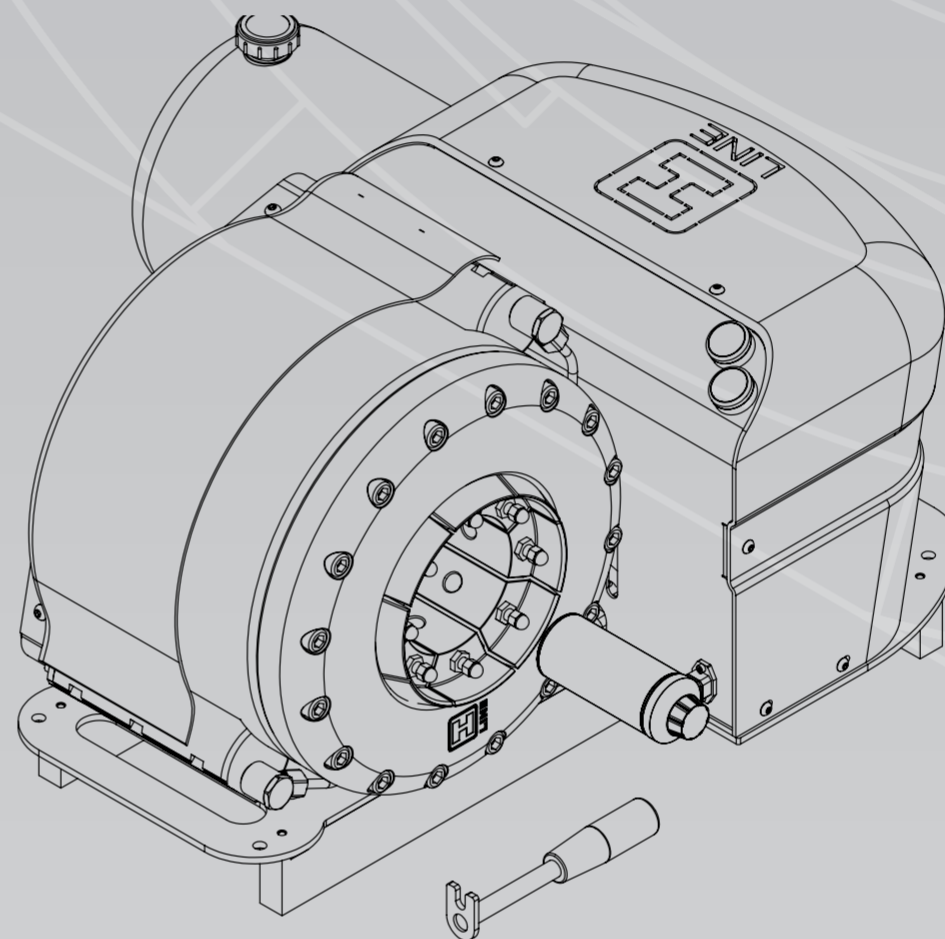
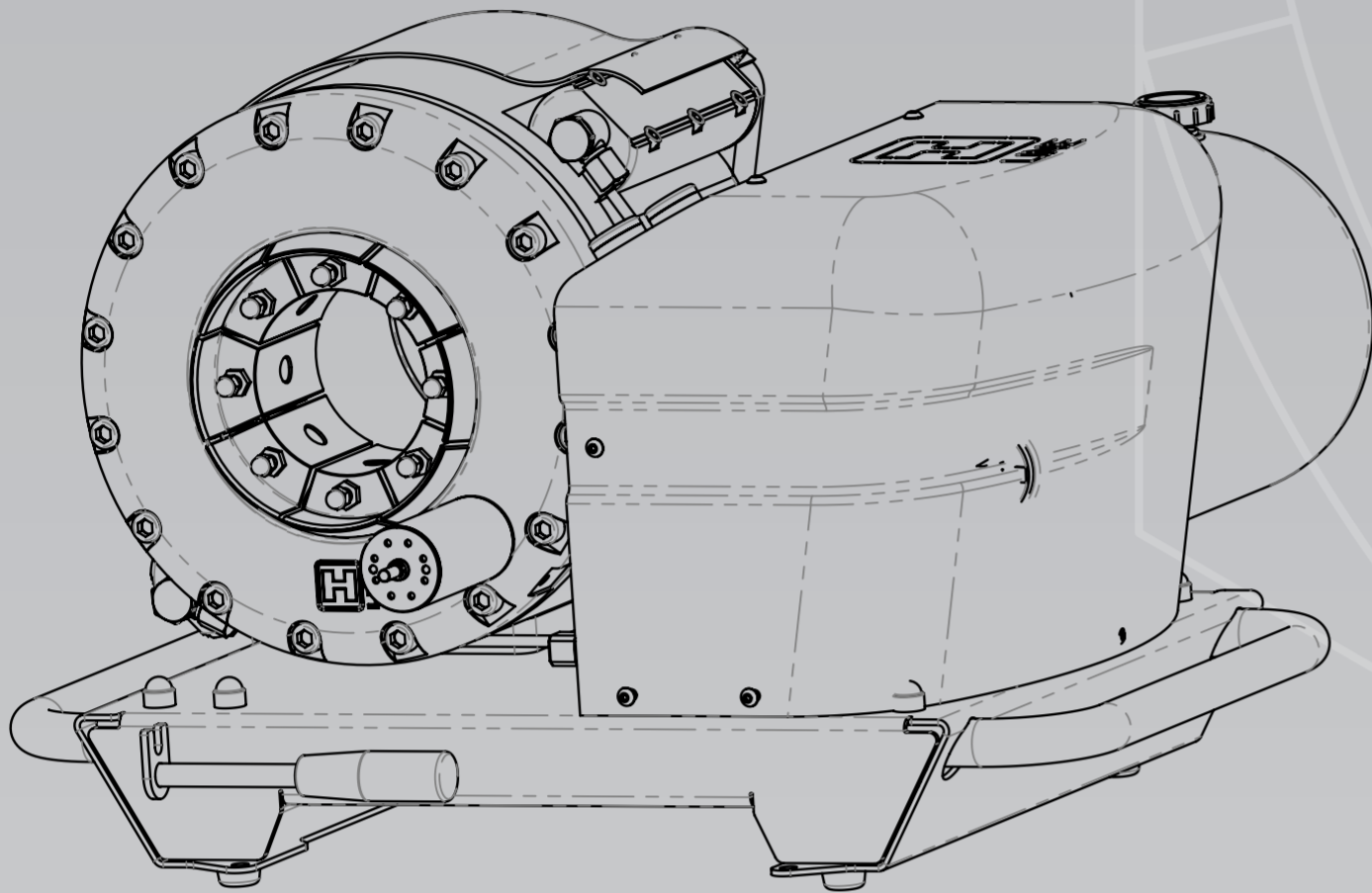

## H-Line Crimpers - Versatile field performance

Ideally suited for service vans and is operated by 12 or 24 volts. All parts are made of high quality aluminium AND steel to ensure a long lifetime. The machine have a strong crimping force up to 2320kN.

### TECHNICAL DATA

Crimping force in kN 275Bar.....	2000
Crimping force in metric tons.....	200
Crimping force in kN 320Bar.....	2320
Crimping force in metric tons.....	232
Crimping range diameter (mm).....	6-87
Hose size 2SN* (inch).....	.2
Hose size 4SP* (Inch).....	1 1/2
Hose size 6SP* 2320kN Machine (inch).....	1 1/2
Die Set .....	H32
Max travel of dies in (mm).....	33
Max opening without dies (mm).....	132
Master die D/L (mm).....	99/78
Machine control.....	Micrometer Screw
Motor size in 12V (kW).....	1,6
Motor size in 24V (kW).....	2,2
Full open to close in sec.....	15
Full cycle open-close-open in sec.....	30
Noise level dBA.....	84
Oil (l).....	8
Colour.....	Black / Orange

\*Hose 2SN\*: 2" EgeFlex 2 CO 2 layers Steel wire. Ferrule: 4200 Serie  
 \*Hose 4SP: 1 1/2" IsoBar 350 CO Rock X-Flex - 4SP- High Pressure Hose  
 \*Hose 6SP: 1 1/2" IsoBar 350 CO Rock X-Flex - 6SP- High Pressure Hose  
 Ferrule: 4700 Serie  
 \*Hose 6SP: 1 1/2" dn38 Manuli XtraFlex - Spiralfit Manuli Fitting, Spiralfit Ferrule

### DIES AND PART NUMBER

H32-10 .....	9060-32-10
H32-12 .....	9060-32-12
H32-14 .....	9060-32-14
H32-16 .....	9060-32-16
H32-19 .....	9060-32-19
H32-22 .....	9060-32-22
H32-26 .....	9060-32-26
H32-30 .....	9060-32-30
H32-34 .....	9060-32-34
H32-39 .....	9060-32-39
H32-45 .....	9060-32-45
H32-51 .....	9060-32-51
H32-57 .....	9060-32-57
H32-63 .....	9060-32-63
H32-69 .....	9060-32-69
H32-74 .....	9060-32-74
H32-78 .....	9060-32-78

### DESIGNATION AND PART NUMBER

H32DC 12V 2000kN .....	9028-00-15
H32DC 12V 2000kN LW .....	9028-00-89-1
H32DC 24V 2000kN .....	9028-00-16
H32DC 12V 2320kN .....	9028-00-89

### H32 ACCESSORIES

QC-plate H32 .....	9028-00-26
QC tool H32 .....	9028-00-09

### DIMENSIONS

Widht/ Depth/ Height .....	631x416x409 mm
Weight .....	115 kg
Widht/ Depth/ Height LW .....	595x627x371mm
Weight LW .....	67 kg

